

MATHEMATICS

KEY STAGE 2 2003

TEST B

LEVELS

3-5

CALCULATOR ALLOWED

PAGE	MARKS
5	
7	
9	
11	
13	
15	
17	
19	
TOTAL	

BORDERLINE
CHECK

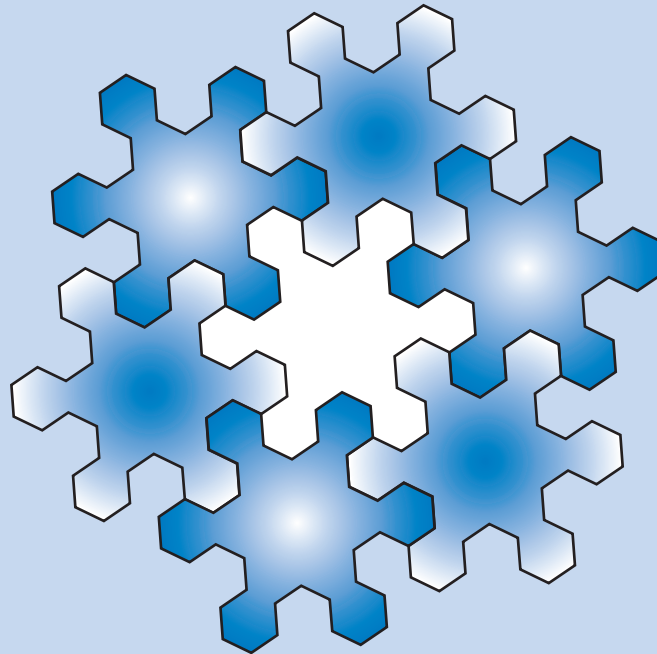

First Name

Last Name

School

Instructions

You **may** use a calculator to answer any questions in this test.

Work as quickly and as carefully as you can.

You have **45 minutes** for this test.

If you cannot do one of the questions, **go on to the next one**.

You can come back to it later, if you have time.

If you finish before the end, **go back and check your work**.

Follow the instructions for each question carefully.



This shows where you need to put the answer.

If you need to do working out, you can use any space on a page.

Some questions have an answer box like this:



Show
your **method**.
You may get
a mark.



For these questions you may get a mark for showing your method.

1

Write in the missing numbers.



$$37 \times \boxed{} = 111$$

$$225 - \boxed{} = 150$$

$$\boxed{} \div 4 = 21$$

1a
1 mark1b
1 mark1c
1 mark**2**

Here are five digit cards.



Use all five digit cards once to make this sum correct.



$$\begin{array}{r}
 \boxed{} \\
 \boxed{} \boxed{} \\
 + \boxed{} \boxed{} \\
 \hline
 60
 \end{array}$$

2
1 mark

3

Here is a clock.

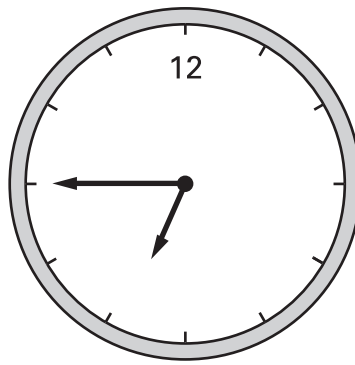

How many minutes is it **until** this clock shows 7:30?



minutes



3a

1 mark

Here is another clock.

14 : 53

What time will the clock show in 20 minutes?



3b

1 mark

4

There are **5 balloons** in a **packet**.

There are **18 packets** in a **box**.

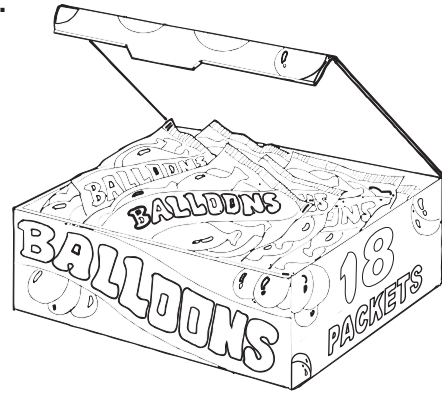
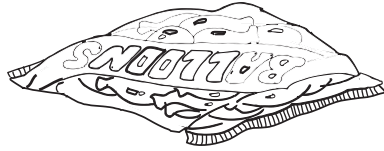

How many balloons are there altogether in a **box**?



4a

1 mark

There are 5 balloons in a packet.

Kofi needs **65 balloons**.

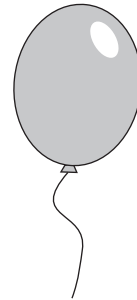

How many **packets** does he need?



4b

1 mark

5

Here is a design and a mirror line.

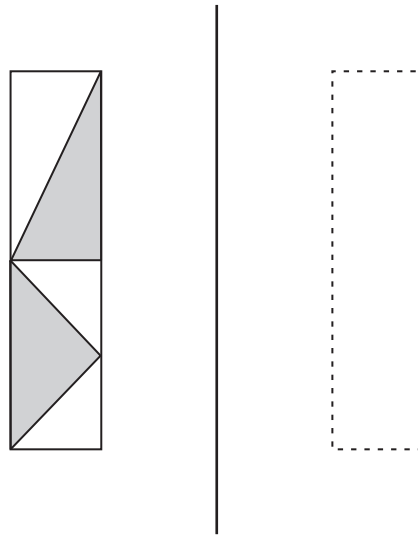

mirror line

Which **one** of the designs below is the reflection of the design in the mirror line?

Tick (✓) the correct design.

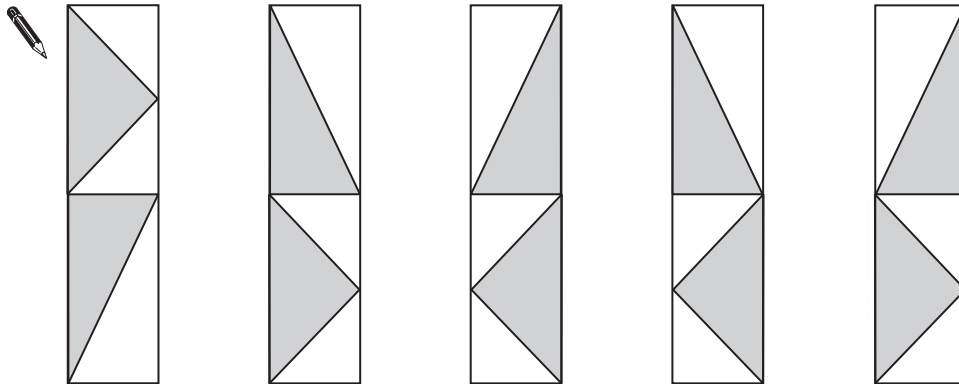

5

1 mark

6

Some children collect cans for recycling.

Here is a chart of how many cans they collect in the first week.

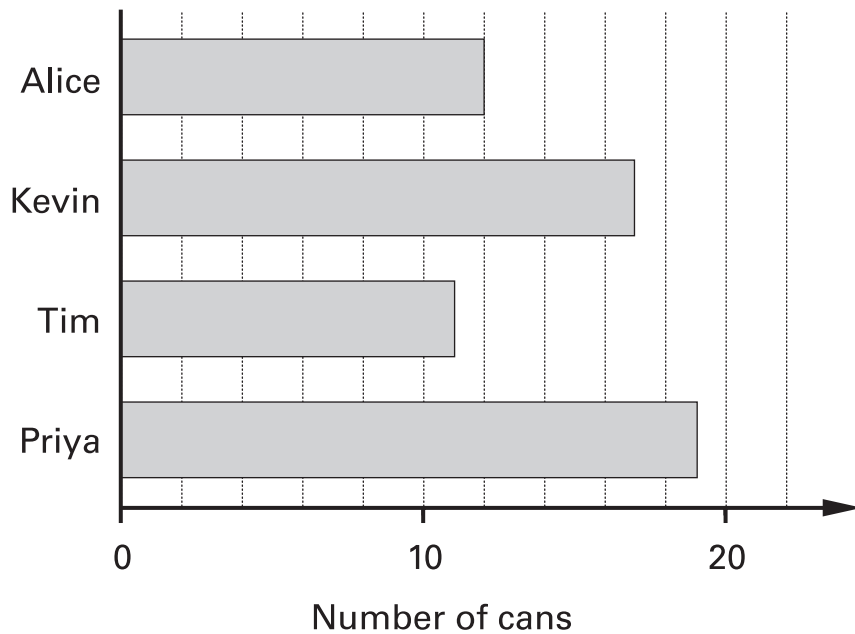

How many cans has Kevin collected?



6a

1 mark

Alice's **target** is to collect **30** cans.

How many **more** cans does Alice need to reach her target?



6b

1 mark

7

Hayley makes a sequence of numbers.

Her rule is

'find half the last number then add 10'

Write in the next two numbers in her sequence.



36

28

24



7i



7ii

2 marks

8

Here is the net of a cube with no top.

The shaded square shows the bottom of the cube.

Draw an extra square to make the net of a cube which does have a top.

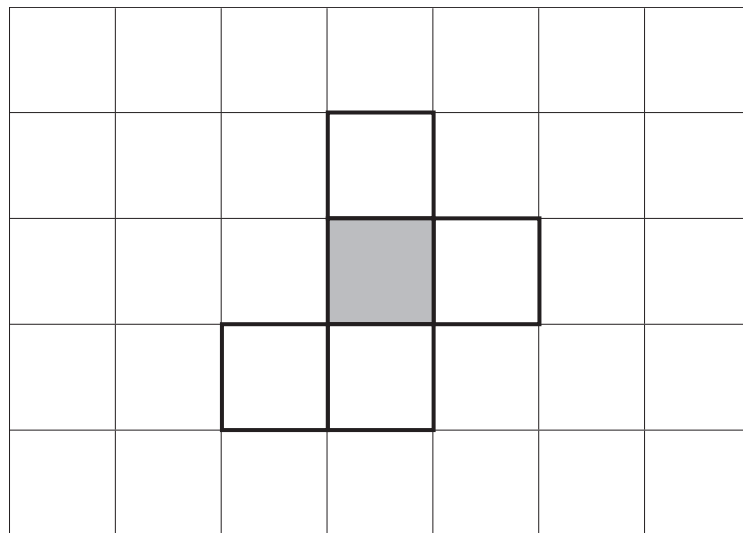

8

1 mark

9

These are the prices in a fish and chip shop.

Fish.....	£1.95
Chips small bag.....	55p
large bag.....	70p
Peas.....	38p

Luke has **£3**

He wants to buy one fish, peas and two large bags of chips.

How much **more** money does he need?



Show your **method**.
You may get a mark.



> 9i
> 9ii
2 marks

10

Draw **two straight lines** from point **A** to divide the shaded shape into a square and two triangles.

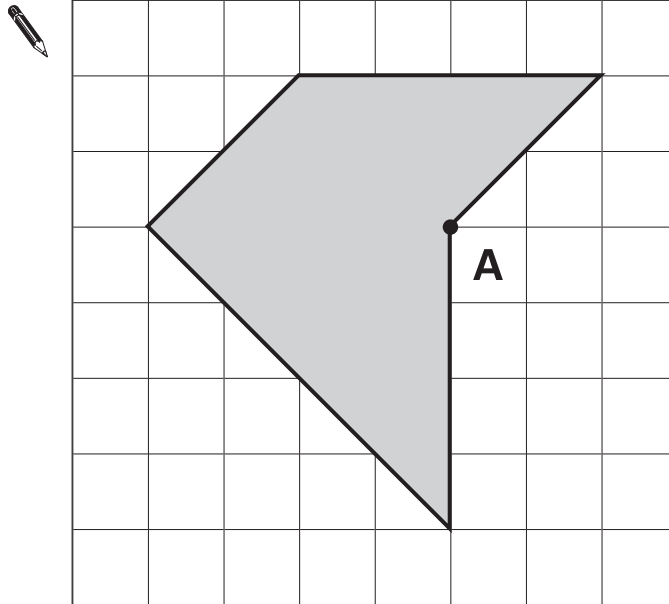

> 10
1 mark

11



The temperature **inside** an aeroplane is **20°C**.

The temperature **outside** the aeroplane is **-30°C**.

What is the **difference** between these temperatures?



degrees

> 11
1 mark

12

Karen makes a fraction using two number cards.

She says,

'My fraction is equivalent to $\frac{1}{2}$

One of the number cards is 6'

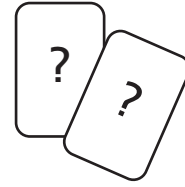

What could Karen's fraction be?

Give both possible answers.



 or

> 12i
> 12ii
2 marks

13

Write what the **three** missing digits could be in this calculation.



--	--

 ×

--

 =

3	7	8
---	---	---

> 13
1 mark

14

Here is a diagram for sorting numbers.

Write **one number** in each white section of the diagram.



	less than 1000	1000 or more
multiples of 20		
not multiples of 20		

> 14i
> 14ii
2 marks

15

Write these lengths in order, starting with the shortest.

$\frac{1}{2}$ m

3.5cm

25mm

20cm



--	--	--	--

shortest

> 15
1 mark

16

In this sequence each number is double the previous number.

Write in the missing numbers.



3

6

12

24

48

17



Here are the **start** and **finish** times of some children doing a sponsored walk.

	Start time	Finish time
Claire	9:30	10:55
Ruth	9:35	11:05
Dan	9:40	11:08
Tim	9:45	11:05

How much longer did Claire take than Tim?



18

This fence has three posts, equally spaced.

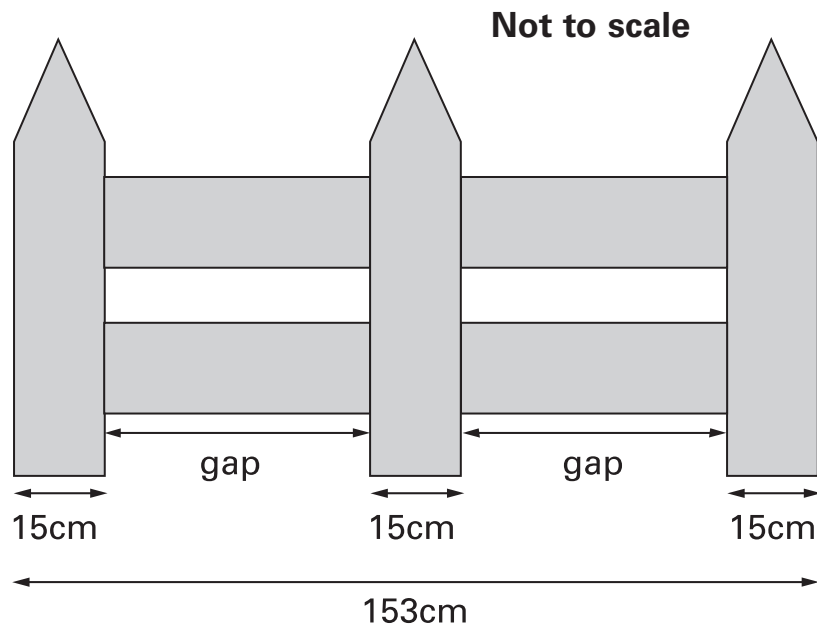

Each post is **15 centimetres** wide.

The length of the fence is **153 centimetres**.

Calculate the length of **one gap** between two posts.

Show your **method**.
You may get a mark.

cm

> 18i
> 18ii
2 marks

19Calculate $\frac{3}{8}$ of 980

19

1 mark

20**k**, **m** and **n** each stand for a whole number.

They add together to make 1500

$$k + m + n = 1500$$

m is **three times** as big as **n**.**k** is **twice** as big as **n**.Calculate the numbers **k**, **m** and **n**.

Show
your **method**.
You may get
a mark.

k =**m** =**n** =

20i



20ii

2 marks



Cheddar cheese costs £7.50 for 1kg.

Marie buys 200 grams of cheddar cheese.

How much does she pay?



£

21a

1 mark

Cream cheese costs £3.60 for 1kg.

Robbie buys a pot of cream cheese for 90p.

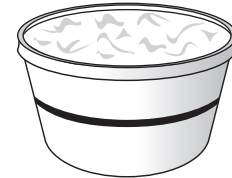

How many grams of cream cheese does he buy?



Show your **method**.
You may get a mark.

grams

21bi

21bii

2 marks

22

Here is a square spinner.

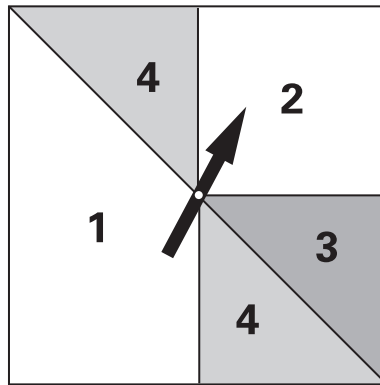

Look at these statements.

For each one put a tick (✓) if it is **correct**.
Put a cross (✗) if it is **not correct**.



'4' is the **most likely** score.

'2' and '4' are **equally likely** scores.

Odd and even scores are **equally likely**.

A score of '3' or more is **as likely as** a score of less than '3'.

> 22i

> 22ii

2 marks

23

This diagram shows four regular hexagons.

Shade in **one third** of the diagram.

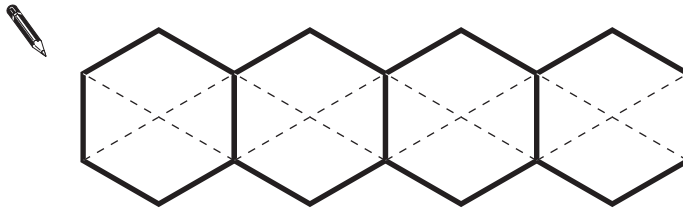

23

1 mark

24

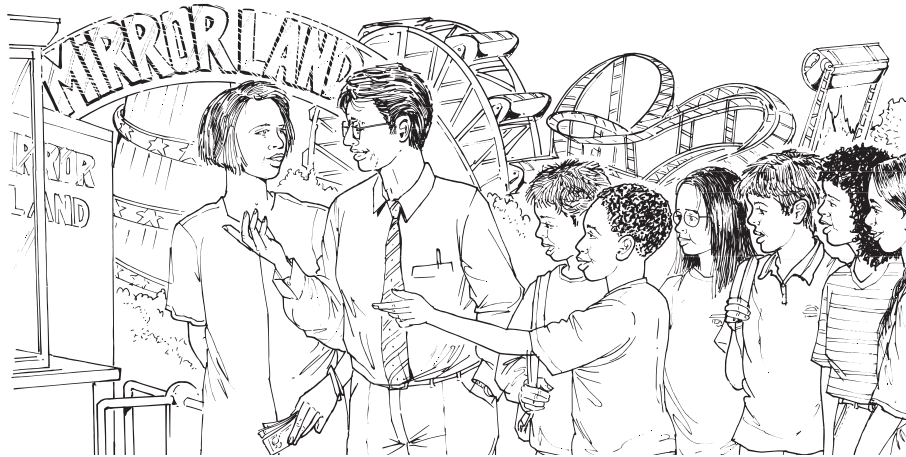

250 000 people visited a theme park in one year.

15% of the people visited in April and

40% of the people visited in August.

How many people visited the park in the rest of the year?



Show your **method**.
You may get a mark.



24i



24ii

2 marks

© Qualifications and Curriculum Authority 2003

QCA key stage 2 team, 83 Piccadilly, London W1J 8QA

Order refs:

QCA/03/1014 (pupil pack)

QCA/03/1009 (mark schemes pack)